

DISCUSSION PAPER SERIES

No. 7202

CEPR/EABCN No. 41/2009

**FINANCIAL (IN)STABILITY,
SUPERVISION AND LIQUIDITY
INJECTIONS: A DYNAMIC GENERAL
EQUILIBRIUM APPROACH**

Gregory de Walque, Olivier Pierrard and
Abdelaziz Rouabah

INTERNATIONAL MACROECONOMICS

€ABCN

Euro Area Business Cycle Network
WWW.EABCN.ORG



Centre for **E**conomic **P**olicy **R**esearch

www.cepr.org

Available online at:

www.cepr.org/pubs/dps/DP7202.asp

FINANCIAL (IN)STABILITY, SUPERVISION AND LIQUIDITY INJECTIONS: A DYNAMIC GENERAL EQUILIBRIUM APPROACH

Gregory de Walque, National Bank of Belgium and University of Namur
Olivier Pierrard, Central Bank of Luxembourg and Catholic University of Louvain
Abdelaziz Rouabah, Central Bank of Luxembourg

Discussion Paper No. 7202
CEPR/EABCN No. 41/2009
March 2009

Centre for Economic Policy Research
53–56 Gt Sutton St, London EC1V 0DG, UK
Tel: (44 20) 7183 8801, Fax: (44 20) 7183 8820
Email: cepr@cepr.org, Website: www.cepr.org

This Discussion Paper is issued under the auspices of the Centre's research programme in **INTERNATIONAL MACROECONOMICS**. Any opinions expressed here are those of the author(s) and not those of the Centre for Economic Policy Research. Research disseminated by CEPR may include views on policy, but the Centre itself takes no institutional policy positions.

The Centre for Economic Policy Research was established in 1983 as an educational charity, to promote independent analysis and public discussion of open economies and the relations among them. It is pluralist and non-partisan, bringing economic research to bear on the analysis of medium- and long-run policy questions.

These Discussion Papers often represent preliminary or incomplete work, circulated to encourage discussion and comment. Citation and use of such a paper should take account of its provisional character.

Copyright: Gregory de Walque, Olivier Pierrard and Abdelaziz Rouabah

CEPR Discussion Paper No. 7202

March 2009

ABSTRACT

Financial (In)stability, Supervision and Liquidity Injections: A Dynamic General Equilibrium Approach*

We develop a dynamic stochastic general equilibrium model with an heterogeneous banking sector. We introduce endogenous default probabilities for both firms and banks, and allow for bank regulation and liquidity injection into the interbank market. Our aim is to understand the interactions between the banking sector and the rest of the economy, as well as the importance of supervisory and monetary authorities to restore financial stability. The model is calibrated against real US data and used for simulations. We show that Basel regulation reduces the steady state but improves the resilience of the economy to shocks, and that moving from Basel I to Basel II is procyclical. We also show that liquidity injections relieve financial instability but have ambiguous effects on output fluctuations.

JEL Classification: E13, E20, G21 and G28

Keywords: banking sector, central bank, default risk, DSGE and supervision

Gregory de Walque
National Bank of Belgium
Research Department
Boulevard de Berlaymont, 14
1000 Brussels
Belgium
Email: gregory.dewalque@nbb.be

Olivier Pierrard
Central Bank of Luxembourg
Bd Royal, 2
L-2983 Luxembourg
LUXEMBOURG
Email: olivier.pierrard@bcl.lu

For further Discussion Papers by this author see:
www.cepr.org/pubs/new-dps/dplist.asp?authorid=146955

For further Discussion Papers by this author see:
www.cepr.org/pubs/new-dps/dplist.asp?authorid=157661

Abdelaziz Rouabah
Central Bank of Luxembourg
Bd Royal, 2
L-2983 Luxembourg
LUXEMBOURG
Email: abdelaziz.rouabah@bcl.lu

For further Discussion Papers by this author see:
www.cepr.org/pubs/new-dps/dplist.asp?authorid=161108

* The publication of this Paper is funded by the Euro Area Business Cycle Network (www.eabcn.org). This Network provides a forum for the better understanding of the euro area business cycle, linking academic researchers and researchers in central banks and other policy institutions involved in the empirical analysis of the euro area business cycle. The views expressed in this paper are personal views of the authors and do not necessarily reflect those of the National Bank of Belgium, the Central Bank of Luxembourg or the Eurosystem.

Submitted 04 February 2009

1 Introduction

In neoclassical models, the capital market is perfectly competitive and investment is simply determined by the marginal cost of capital. More fundamentally, in these models, the capital market is not distorted by taxes, transaction or bankruptcy costs, imperfect information or any other friction which limits access to credit, so the Modigliani and Miller (1958) theorem holds meaning that financial and credit market conditions become irrelevant and cannot affect real economic outcomes. However, credit market imperfections and financial agents' behavior are often considered a crucial contributing factor to the severity of crises, for instance during the Great Depression or more recently the subprime crises and associated financial turmoil. This central role of the credit market may in turn explain why banking remains so heavily regulated despite the significant deregulation in recent decades in many other industries. This may also explain why central banks react so rapidly to financial crises, despite the risk of creating moral hazard.

The main objective of this paper is to build a dynamic stochastic general equilibrium model with imperfections in the credit market, such that the Modigliani and Miller (1958) theorem no longer holds. More precisely, following Goodhart et al. (2006), we develop an endogenous and heterogeneous banking sector, and allow for bank regulation and liquidity injections. We embed this banking sector representation in an otherwise standard real business cycle model (hereafter RBC, see King and Rebelo (1999) for an extensive exposition). We start from the RBC model because it is now widely accepted as a benchmark in the literature. Moreover, in the limiting case of no default rates and no supervisory and monetary authorities, our model generates results similar to those of the RBC model. We then develop a plausible calibration and use our model to understand the interactions between the banking sector and the rest of the economy, as well as the role of supervisory and monetary authorities in restoring financial stability.

Carlstrom and Fuerst (1997), Bernanke et al. (1999), Cooley et al. (2004), Kiyotaki and Moore (1997) or Iacovello (2005) introduce credit market frictions (asymmetry of information and agency costs, limited contract enforceability, collateral constraints,...) in dynamic general equilibrium models and show that frictions act as a financial accelerator. These models only focus on the demand side of the credit market and banks are limited to act as intermediaries between households (lenders) and firms (borrowers). Meh and Moran (2004) argue that banks themselves are also subject to frictions in raising loanable funds and show that the supply side of the credit market (bank balance sheet) also contributes to shock propagation. However, their capital-asset ratio is market-determined rather than originating from regulatory requirements. Markovic (2006) develops a closely related model in which banks must raise capital reserves (or reduce their loan supply) to fulfill regulatory requirements. Results suggest that the bank

capital channel contributes significantly to the monetary transmission mechanism, along with the corporate balance sheet channel. Goodfriend and McCallum (2007) and Christiano et al. (2007) formulate quantitative models to assess the relevance of a detailed banking sector (and hence the importance of distinguishing among the various short term interest rates) for monetary policy. Gerali et al. (2008) augment these papers by introducing imperfect competition among banks.¹

All the papers mentioned above use homogeneous banks and the interbank market either collapses or amounts to a connection with the central bank. But as mentioned in Goodhart et al. (2006), ignoring bank heterogeneity and the existence of a true interbank market obscure all the relationships between banks which interest supervisory authorities and central banks. Moreover, most papers limit bank choices to collecting deposits and supplying loans, forgetting possibilities as other balance sheet choices or default. Goodhart et al. (2005) develop a model including an heterogeneous banking sector with an explicit interbank market, optimal balance sheet choices and endogenous default rates. Since the main focus of their paper is financial fragility, a financial regulator imposes a range of penalties in case of default or non respect of capital adequacy ratio. A central bank is also included on the interbank market. However, if the “core” banking sector is extensively developed and micro-founded, the “periphery” agents are modelled through reduced form equations. In addition, this is only a 2-period model which cannot track dynamic effects of shocks or policies.²

Our model includes one agent that borrows (representative firm) and one that lends (representative household), as well as a banking market composed of two banks (a net lender and a net borrower on the interbank market) with endogenous balance sheet decisions. We assume that agents (firms and banks) may default on their financial obligations, subject to default costs, and these defaults act as financial accelerators. Our model is fully microfounded in the sense that all agents maximize profits or utility under constraints. Moreover, we have capital regulation rules set by a supervisory authority and we allow for monetary policy through liquidity injections into the interbank market. We therefore have a banking sector representation close to Goodhart et al. (2005), but we embed it in a fully micro-founded dynamic (intertemporal) stochastic general equilibrium model. As underlined in Borio and Zhu (2007), this is the only framework in which dynamic interactions between agents and policy effects can be properly assessed.

We use US data on interest rates, default rates, bank balance sheet and production to calibrate the model. We introduce a productivity shock (TFP shock) and compare our simulation results

¹This literature review is far from being exhaustive and we concentrate on dynamic general equilibrium models. For an extended survey, see for instance VanHoose (2008).

²Decisions under uncertainty (2 possible states) are taken in period 1. In period 2 the state of the world is revealed and contracts are settled.

to US data. We show that the productivity shock alone does not allow to reproduce all US stylized facts (for instance the procyclicality of bank profits) but adding a - positively correlated - market book shock improves the results. We also show that imposing a Basel regulation (minimum capital ratio) reduces the steady state but improves the resilience of the economy to shocks, and that moving from Basel I to Basel II (more risk-sensitive requirements) is procyclical. These effects are however quantitatively weak because mitigated by the buffer banks hold on top of the required minimum capital. We then illustrate the subprime crisis by replacing the productivity shock by a negative market book shock. We see that a banking shock may have dramatic impacts on the rest of the economy and that central bank reaction (liquidity injections) strongly reduces the negative effects on GDP at impact but creates distortions in the medium-run. However, liquidity injections have unambiguous and positive effects on financial stability.

Section 2 introduces the model. Section 3 describes the calibration. Section 4 compares our numerical simulations with US data and explains the role of endogenous defaults and the Basel regulation. Section 5 looks at the effect of a market book shock. Section 6 concludes.

2 Model

We depart from the standard RBC model with a perfectly competitive capital (or credit) market between households/lenders and firms/borrowers by introducing a banking sector. More precisely, we assume that households deposit savings with a bank and that firms borrow capital from a bank. In this setup, bank deposits (from households) may differ from bank loans (to firms) and the interest rate on deposits (lending rate) may differ from the interest rate on loans (borrowing rate) generating an interest rate spread.

A second departure from the standard model is the introduction of an interbank market: banks receiving deposits from households (excess liquidity) are different from banks supplying loans to firms (liquidity shortage) and equilibrium is restored through the interbank market.³ The interbank interest rate is free to move (no central bank intervention) or alternatively, the central bank may inject or remove liquidity to influence the interbank rate. Again, the interbank interest rate may differ from both the lending rate and the borrowing rate.

We also introduce endogenous probabilities of default for firms and borrowing banks. In other words, a firm default may lead to a bank default on the interbank market. It is worth noting that we do not have a default possibility for the lending banks. We believe this is a fair rep-

³In the subsequent analysis, we call “borrowing banks” those who borrow on the interbank market and lend to firms, and “lending banks” those who lend on the interbank market and collect deposits from households. Alternatively, we could argue we have two types of specialized banks: deposit banks collecting deposits and merchant banks lending to firms.

representation of reality because a deposit guarantee scheme exists in all OECD countries. Our representation therefore implies that banks take risks (uncertain net return on investment) instead of households (net investment return always perfectly known). The fact that banks have different mechanisms (own funds commitment, insurance fund, portfolio diversification,...) to protect themselves against these risks justifies their role as financial intermediaries.

Finally, we have a supervisory authority, fixing own fund requirements for banks. These requirements may be independent from the business cycle (Basel I, based on asset type) or risk-sensitive (Basel II, based on asset type and asset quality). We therefore have six agents in our model: firms, borrowing banks, lending banks, households, a supervisory authority and a central bank. The relationships between these six agents are summarized in Figure 1. Without defaults and hence without supervision, the distinction between the three interest rates would become irrelevant and our model would collapse into a standard RBC one.

2.1 Firms

Risk-neutral firms choose employment, new borrowing and repayment rate on past borrowing from profit maximization.⁴ As in Shubik and Wilson (1977), Dubey et al. (2005) or Elul (2008), defaulters are not excluded from the market but bear costs. Costs are both non pecuniary (disutility or “social stigma”: reputation losses, pangs of conscience) and pecuniary (higher search costs to obtain new loans because of the bad reputation). The firm maximization program is:

$$\max_{N_t, L_t^b, \alpha_t} \sum_{s=0}^{\infty} E_t \left[\tilde{\beta}_{t+s} \left\{ \pi_{t+s}^f - d_f (1 - \alpha_{t+s}) \right\} \right], \quad (1)$$

under the constraints:

$$K_t = (1 - \tau)K_{t-1} + \frac{L_t^b}{1 + r_t^b}, \quad (2)$$

$$\pi_t^f = \epsilon_t \mathcal{F}(K_t, N_t) - w_t N_t - \alpha_t L_{t-1}^b - \frac{\gamma}{2} \left((1 - \alpha_{t-1}) L_{t-2}^b \right)^2, \quad (3)$$

$$\tilde{\beta}_{t+s} = \beta^s \frac{\mathcal{U}_{C_{t+s}}}{\mathcal{U}_{C_t}}. \quad (4)$$

Equation (2) is the law of motion for capital. Capital K_t depreciates at a rate τ and firms borrow L_t^b at a price $1/(1 + r_t^b)$ to refill their capital stock.⁵ Equation (3) defines profit. The firms produce goods using capital and labor N_t as input, and ϵ_t is a total factor productivity shock.

⁴Risk-neutrality for firms is a usual assumption in the RBC literature.

⁵The interest rate is predetermined meaning it is fixed (contract between firms and banks) at the borrowing time t and not at the repayment time $t + 1$. We think this is a plausible representation of reality. Moreover, without pre-determination, the endogenous default choice would be irrelevant because it would be totally offset by an interest rate increase. In reality, firms may also finance investment with own funds or through direct access to financial markets, but this is beyond the scope of this paper. We assume firms finance investment with bank credit.

They pay a wage w_t to workers and reimburse their previous period borrowing L_{t-1}^b . They choose what proportion α_t of their previous borrowing they want to repay, knowing that they will have to pay tomorrow a quadratic search cost on any defaulted amount (and also bear a disutility). Firms are ultimately owned by households and their discount factor is therefore given by equation (4), where \mathcal{U}_{C_t} represents the marginal utility of consumption and β the discount factor.

The first order conditions are developed in Appendix A.

2.2 Banks borrowing from the interbank market (merchant banks)

Risk-averse merchant banks choose fund allocation (loans L_t^b to firms, market book B_t^b , borrowing D_t^{bd} from the interbank market and own funds F_t^b) and their repayment rate on past borrowing to maximize profits.⁶ As for firms, defaulters are not excluded but have both disutility and pecuniary costs.⁷ We follow Goodhart et al. (2005) by assuming a positive utility for the buffer of own funds F_t^b above the minimum capital requirement imposed by the financial supervisory authority which fixes the coverage ratio of risky assets k , together with $\bar{\omega}_t$ and $\tilde{\omega}$ the respective weights on loans and on the market book. In addition, $\bar{\omega}_t$ may vary over time, see subsection 2.6.⁸ The bank maximization program is:

$$\max_{\delta_t, D_t^{bd}, L_t^b} \sum_{s=0}^{\infty} E_t \left[\tilde{\beta}_{t+s} \left\{ \ln \left(\pi_{t+s}^b \right) - d_{\delta} (1 - \delta_{t+s}) + d_{F^b} \left(F_t^b - k \left[\bar{\omega}_t L_t^b + \tilde{\omega} B_t^b \right] \right) \right\} \right], \quad (5)$$

under the constraints:

$$F_t^b = (1 - \zeta_b) F_{t-1}^b + v_b \pi_t^b, \quad (6)$$

$$\begin{aligned} \pi_t^b &= \alpha_t L_{t-1}^b + \frac{D_t^{bd}}{1 + i_t} - \delta_t D_{t-1}^{bd} - \frac{L_t^b}{1 + r_t^b} - \frac{\omega^b}{2} \left((1 - \delta_{t-1}) D_{t-2}^{bd} \right)^2 \\ &\quad + \zeta_b (1 - \alpha_{t-1}) L_{t-2}^b + \phi_t^b, \end{aligned} \quad (7)$$

with $\zeta_b, \tilde{\zeta}_b$ and $v_b \in [0, 1]$. Equation (6) states that own funds are increased each period by the share v_b of profits that are not redistributed to the households-shareholders. Furthermore, a small fixed proportion ζ_b of the own funds are put in an insurance fund managed by a public authority. Equation (7) defines the period profit. The bank borrows D_t^{bd} on the interbank

⁶See for instance Goodhart et al. (2005) for a similar risk-aversion assumption.

⁷See previous subsection for a justification.

⁸In practice, the regulator sets a minimum capital requirement and penalties are paid in case of violation. Since we want to rule out a corner solution in our model, we simply assume that banks want to keep a buffer above the required minimum in order to avoid penalties. This buffer assumption does not seem unrealistic and is found in data (see section 3). As underlined in Borio and Zhu (2007), crossing the capital threshold is extremely costly for a bank (restrictive supervisory actions, market reaction, reputation losses) and would be regarded as the “kiss of death”.

market at a price $1/(1+i_t)$. It chooses the fraction δ_t of past borrowing it wants to pay back, knowing that it will have to pay tomorrow a quadratic search cost on her defaulted amount. Because of the existence of the insurance fund, the bank is able to recover a fraction ζ_b of the firms' defaulted amount. The last variable on the right-hand side collects the market book terms. The market book net return is $(1+\rho_t)B_{t-1}^b - B_t^b$. We assume an exogenous market book volume $B_t^b = \bar{B}^b$.

The first order conditions are developed in Appendix A.

2.3 Banks lending to the interbank market (deposit banks)

Risk-averse deposit banks choose fund allocation (loans D_t^{bs} to the interbank market, market book B_t^l , deposits D_t^l from households and own funds F_t^l) from profit maximization. As the merchant banks, they derive utility from the buffer of own funds above the capital requirement imposed by the supervisory authority. The latter fixes the coverage ratio of risky assets k , as well as $\bar{\omega}$ and $\tilde{\omega}$, the weights associated respectively to interbank loans and market book. Their maximization program is

$$\max_{D_t^{bs}, D_t^l} \sum_{s=0}^{\infty} E_t \left[\tilde{\beta}_{t+s} \left\{ \ln(\pi_{t+s}^l) + d_{Fl} \left(F_t^l - k \left[\bar{\omega} D_t^{bs} + \tilde{\omega} B_t^l \right] \right) \right\} \right], \quad (8)$$

under the constraints:

$$F_t^l = (1 - \zeta_l) F_{t-1}^l + v_l \pi_t^l, \quad (9)$$

$$\pi_t^l = \delta_t D_{t-1}^{bs} + \frac{D_t^l}{1+r_t^l} - D_{t-1}^l - \frac{D_t^{bs}}{1+i_t} + \zeta_l (1 - \delta_{t-1}) D_{t-2}^{bs} + \phi_t^l, \quad (10)$$

with ζ_l , ξ_l and $v_l \in [0, 1]$. Equation (9) displays the own funds dynamic: own funds F_t^l are increased each period by the share v_l of profits that are not redistributed to the households-shareholders. Furthermore, a small fixed proportion ζ_l of the own funds are put in an insurance fund managed by a public authority. Equation (10) defines the bank's profit. It pays a net return $r_t^l/(1+r_t^l)$ on deposits from households and receives a gross return $i_t/(1+i_t)$ from loans on the interbank market, the net return varying along with the merchant banks default rate $(1-\delta_t)$. Note that a fraction ζ_l of the defaulted amount (by the defaulting merchant banks) is paid back to the deposit banks from the insurance fund managed by the public authority. We assume that the lending banks never default, that is they always repay 100% of deposits. The last variable on the right-hand side collects the market book terms. The market book net return is $(1+\rho_t)B_{t-1}^l - B_t^l$. We assume exogenous market book volume $B_t^l = \bar{B}^l$.

The first order conditions are developed in Appendix A.

2.4 Households

As in the standard RBC literature, we assume risk-averse households maximizing the utility of consumption C_t and leisure $1 - N_t$. We also impose a target in deposits (households do not like deposits differing from their long run optimal level) through a quadratic disutility term.⁹ The household maximization program is:

$$\max_{N_t, C_t} \sum_{s=0}^{\infty} \beta^s E_t \left[\mathcal{U}(C_{t+s}) + \bar{m} \ln(1 - N_{t+s}) - \frac{\chi}{2} \left(\frac{D_{t+s}^l}{1 + r_{t+s}^l} - \frac{\bar{D}^l}{1 + r^l} \right)^2 \right], \quad (11)$$

under the budget constraint:

$$C_t + \frac{D_t^l}{1 + r_t^l} = w_t N_t + D_{t-1}^l + \pi_t^f + (1 - v_b) \pi_t^b + (1 - v_l) \pi_t^l. \quad (12)$$

The first order conditions are developed in Appendix A.

2.5 Central bank

In the long run, we assume equilibrium in the interbank market, that is $D^{bd} = D^{bs}$. However, in the short run, the central bank may inject ($M_t > 0$) or withdraw liquidities ($M_t < 0$) such that:

$$M_t = D_t^{bd} - D_t^{bs}. \quad (13)$$

The liquidity operation M_t follows a simplified McCallum (1994) rule:

$$M_t = \nu (i_t - \bar{i}), \quad (14)$$

with $\nu \geq 0$, such that M_t increases (resp. decreases) when the interbank rate is higher (resp. lower) than the desired value \bar{i} .¹⁰ If $\nu = 0$, there is no central bank intervention and the interbank interest rate clears the interbank market.¹¹

⁹ We introduce the convex disutility term for technical reasons. If $\chi = 0$, both equations (A9) and (A12) give the steady state for r_t^l , leaving D_t^l undetermined (singular matrix). By imposing $\chi > 0$, we force equation (A12) to determine the steady state of D_t^l . Note that in our calibration, χ is kept close to zero to only marginally affect the dynamic properties of the model. Alternatively, we could introduce a bank production function and assume that $D_t^l / (1 + r_t^l)$ deposits only produce $(D_t^l / (1 + r_t^l))^\lambda$ assets. As long as $\lambda \neq 1$, this would allow equation (A9) to determine D_t^l at the steady state.

¹⁰ Since $M_t = 0$ in the long run, \bar{i} must be equal to the equilibrium value of the interbank rate, *i.e.* $\bar{i} = i$.

¹¹ In our model, because of the long run equilibrium in the interbank market, there is no distinction between central bank money and private bank money. In other words, interest and default rates apply to both types of funds. Alternatively, we could assume long run disequilibrium in the interbank market (for instance demand from borrowing firms structurally higher than supply from lending firms). In this case the central bank should permanently supply money $M_t > 0$ and we could distinguish between private bank funds and central bank funds. This alternative route would not change our results.

2.6 Supervisory authority

The supervisory authority fixes the capital requirement ratio k and the weights $\bar{\omega}_t$, $\bar{\omega}$ and $\tilde{\omega}$ associated with the different kinds of risky assets. We assume that under Basel I regulations, all weights are constant and in particular $\bar{\omega}_t = \bar{\omega}$. Basel II regulations offer more sophisticated and informative measures of risks and capital adequacy. In particular, in our model, we assume that the credit weight associated to loans to firms is risk-sensitive. If the expectations of firm default increase, the associated weight also increases:

$$\bar{\omega}_t = \bar{\omega} E_t \left[\left(\frac{\alpha}{\alpha_{t+1}} \right)^\eta \right], \quad (15)$$

with $\eta > 0$.¹²

3 Calibration

We calibrate the model on average historical real quarterly US data (from 1985Q1 to 2008Q2).¹³ The calibration of the banking sector (section 3.1) is mainly based on balance sheet and macro-financial data whereas we build the calibration of the real sector (firms and households, section 3.2) from national account data. The summary of the calibration as well as the implied values for variables are given in Tables 1 and 2. We also provide in Appendix B further empirical evidence on the close relationship between the banking and the real sector activities.

3.1 Banking sector

To match the data, we set the steady state values for the three quarterly real interest rates at $r^b = 1.6\%$ (borrowing rate), $i = 0.7\%$ (interbank rate) and $r^l = 0.35\%$ (deposit rate), implying a discount factor of $\beta = 1/(1 + r^l)$. The average quarterly real return of the Dow Jones from 1985Q1 to 2008Q2 is about 2.2% but we can expect that banks also have higher-yield securities. In our model we therefore assume that the market book offers a real return $\rho = 3\%$. Using the Z-score method (probability that own funds are not sufficient to absorb losses, see Appendix C for details), we find that the quarterly probability of default for banks is 0.1%. This is obviously low but can be explained because the Z-score is computed from aggregate data (one single representative US bank). Computing Z-scores from individual bank data and then aggregating the different results would probably increase the value. Alternatively, we define the bank default rate by the ratio of bankruptcies to banks. The Federal Deposit Insurance Corporation provides data on the number of bank failures and the Bureau of Labor Statistics provides data on the number of closings in the financial sector. This gives respectively 1% and 4% (but this

¹²We could similarly introduce Basel II regulations on interbank loans with $\bar{\omega}_t = \bar{\omega} E_t [(\delta/\delta_{t+1})^\eta]$.

¹³Some of the data we use are only available since 1985, see Appendix B for details.

last number is probably too high since the financial sector is larger than the banking sector and failures are only part of closings). We finally pick the value of 1%, that is $\delta = 99\%$.¹⁴

The aggregate balance sheet of US banks is displayed in Appendix B. It is worth noting that in balance sheet data, interbank and consumer deposits as well as interbank and firm loans are stock variables (as far as we know, no flow data are available). In our model, all these variables have a one-quarter maturity and we cannot distinguish flows from stocks. We therefore calibrate the model to keep the same *ratio* between variables (in the data and in the model), but keeping in mind that their *values* have different meanings (stocks in data and flows in the model). In other words, we impose $D^l/L^b = 2$ and $D^{bd}/L^b = D^{bs}/L^b = 0.5$.¹⁵ Finally, we also impose a market book for each bank equal to firm loans: $B^l = B^b = L^b$. The market book share seems larger than what observed in data but we must again keep in mind that L^b is a stock in data and a flow in the model.

According to the Basel agreement, minimum own funds cannot be lower than 8% of risk-adjusted assets ($k = 0.08$). The latter are defined by associating a risk category (weight) to each balance sheet asset (the riskier the assets, the larger the weight). The weight varies from zero to 150 percent. The interbank market in OECD countries is almost risk-free and a low weight ($\bar{\omega} = 0.05$) seems sensible. The weight of the market book must lie between 0.2 (AAA investments) and 1.5 (riskiest investments) so we choose $\tilde{\omega} = 1.2$. Finally, we assume that the Basel weight for loans to private firms is somewhere in between and set $\bar{\omega} = 0.80$. Although the *official* minimum ratio is 8%, most banks adopt a higher *effective* ratio to avoid any penalty risk and we set this effective ratio at 15%. The whole Basel calibration implies that total own funds represent 25% of total market book, which is slightly lower than what observed in data (about 33%, see Appendix B).

Every period, banks allocate 50% of their profits to own funds ($v_b = v_l = 0.50$) and the remaining 50% are distributed to shareholders. Our model also includes an insurance mechanism. In case of default, 80% of the bad loans are eventually reimbursed by an insurance fund ($\zeta_b = \zeta_l = 0.80$). But it implies that banks must put about 6% of their own funds into this insurance scheme every quarter ($\tilde{\zeta}_b = 5.9\%$ and $\tilde{\zeta}_l = 6.5\%$).

From all these restrictions, we are able to infer values for ω^b (default cost parameter for banks), d_δ (default disutility parameter for banks), d_{F^b} and d_{F^l} (own funds utility parameter for respectively borrowing and lending banks). We also get on average (quarterly figure), that default costs amount to 0.2% of own funds and that the return on own funds (ratio of profits to own

¹⁴In section 4, we compare our simulations to the Z-score series, because the FDIC series is extremely volatile and the BLS series is limited in time.

¹⁵In data, interbank loans do not match interbank deposits because US banks have borrowing/lending relationships with banks abroad. Because we model a close economy, we must force a perfect match between deposits and loans.

funds) is 12%. This is probably a too high return but it could be simply decreased by introducing fixed costs for banks (building, equipment, employment,...).

3.2 Real sector

As usual in RBC models, the consumption utility function \mathcal{U} is logarithmic and employment (or total hours) \bar{N} is normalized to 0.2.¹⁶ The production function $\mathcal{F}(K_t, N_t) = K_t^\mu N_t^{1-\mu}$ is Cobb-Douglas with labor share = 2/3, *i.e.* is $1 - \mu = 2/3$, and the productivity shock is normalized to 1 ($\epsilon = 1$). We assume that capital stock is 10 times higher than production and the depreciation rate of capital is 3%, implying an investment ratio to output of 0.3 ($K/\mathcal{F} = 10$ and $\tau = 3\%$ gives $\tau K/\mathcal{F} = 0.3$). This is higher than what is observed in data and usually used in RBC models ($K/\mathcal{F} = 8$ and $\tau = 2.5\%$ gives $\tau K/\mathcal{F} = 0.2$), but we need this to avoid a negative search cost γ .

The US courts provide quarterly data on business bankruptcies. We divide these data by the number of firms to define the firm default rate and we obtain 5%. Using the same kind of data provided by the Bureau of Labor Statistics, we get a similar value. In our calibration, we therefore set $\alpha = 0.95$.¹⁷ From this, we infer values for γ (firm default cost parameter), d_f (firm default disutility parameter) and \bar{m} (leisure utility parameter). This also implies that default costs for firms represent on average 0.6% of output, that firm profits represent 4% of output and that consumption represents 70% of output (exactly as in data). Finally, the smoothing parameter for deposits is set close to 0 ($\chi = 0.01$) to avoid any dynamic effects (see footnote 9).

4 Simulations

In the RBC tradition, we first check if the model is able to match some important stylized facts. Simulations are driven by autoregressive productivity shocks $\epsilon_t = (\epsilon_{t-1})^{\rho_\epsilon} \exp(u_t^\epsilon)$ with $\rho_\epsilon = 0.95$, $u_t^\epsilon \sim N(0, \sigma_\epsilon^2)$ and $\sigma_\epsilon = 0.01$ (standard in RBC literature). We assume a constant return on market book, a Basel I regime ($\eta = 0$) and no liquidity interventions ($\nu = 0$). We then show how important is the financial accelerator generated by our endogenous default rates. Finally, we explain the effects of the Basel I regulation on both the steady state of the economy and its cyclical properties, and how the latter are affected by moving from Basel I to Basel II (risk-sensitive capital requirements).

4.1 Business cycle moments

We compute real data first and second moments for interest rates, repayment rates, balance sheet components and production, and we compare these moments to those obtained from our simulated data. Real moments are reported in columns “data” of Table 3 and simulated

¹⁶On average, we work about 20% of total available hours: $0.2 \cong (40 \times 42)/(52 \times 7 \times 24)$.

¹⁷In section 4, we compare our simulations to the US courts series, because the BLS series is limited in time.

moments are reported in columns “model”. The model is calibrated to broadly match first moments observed in data. The discrepancy between model and data for δ_t (different sources), L_t^b , D_t^{bd} , D_t^{bs} and D_t^l (stocks *vs.* flows and open *vs.* close economy) has already been documented in section 3.

Regarding the second moments, real data show that all interest rates are volatile, positively correlated with output and highly persistent.¹⁸ Our model does not generate enough volatility (but we do not have an endogenous policy rate) but reproduces the positive correlation as well as the persistence of the three interest rates. Moreover, the correlation between the three interest rates is high, as in data. We are also able to reproduce the procyclicality of the two repayment rates, although we do not get enough volatility for α_t (in the calibration, we impose a quadratic cost for default, a less convex cost would fill - very - partially the gap).

In data, balance sheet components are very volatile, mainly procyclical and highly persistent.¹⁹ The only two countercyclical variables are interbank loans and consumer deposits. We clearly cannot reproduce these last two facts. In our model, without liquidity injections, interbank loans always match interbank deposits. And as in all RBC models, savings are positively correlated with output, unless we change households’ preferences. For the other variables, the model reproduces nicely the volatility and the procyclicality, at the exception of profits and as a result, own funds. The reason is obvious: all fluctuations in our model are driven by the sole productivity shock whereas we can expect that other shocks (for instance stock market shocks) are also important to explain banking sector cyclical properties. In Appendix D, we add a market book shock along to our productivity shock (with a positive correlation between them) and show that it improves the results and provides a much more realistic representation of the banking sector.

Finally, our model fits reasonably well data for GDP, consumption, investment and employment. It is worth noting that all these results directly depend on the model and not on a very specific calibration.²⁰

¹⁸The positive correlation and the high volatility are due to our time history: monetary policy was very active from 1985 onwards and the three interest rates we use are highly correlated with the Fed Fund rate. Starting in 1947, as for instance Stock and Watson (1999), would have produced a negative correlation as well as a much lower volatility.

¹⁹The extreme volatility of profits is explained by the stock market crash in October 1987 (Black Monday). As a result, bank profits fell by about 95% the following quarters.

²⁰For instance, although earlier versions of this paper (see for instance NBB WP 148 or BCL WP 35) are calibrated on Luxembourg data, results are qualitatively similar.

4.2 On the role of endogenous repayment rates

We first explore the effects of endogenous repayment rates from a static analysis. The repayment rate α appears on both sides of the loan market for firms. Assuming a Cobb-Douglas production function (see section 3), and posing $\beta = 1$ and $d_f = 0$, the demand side of the credit market represented by first order conditions (A2), (A3) and (A4), see Appendix A, simplifies in the steady state to:

$$\left(L^b\right)^{1-\mu} = \frac{c}{(1+r^b)}, \quad (16)$$

$$(1-\alpha) = \frac{1}{\gamma L^b}, \quad (17)$$

where $c = \mu \frac{N^{1-\mu}}{\tau^\mu}$ is a constant. Equation (16) is the negatively sloped credit demand and equation (17) indicates that the quadratic penalty costs yield the default rate $(1-\alpha)$ to be decreasing with the demand for loans. On the supply side, first order condition (A7) simplifies to (assuming no insurance fund):

$$\frac{1}{1+r^b} = \alpha - \frac{d_{F^b} k \bar{\omega}}{\lambda^b}, \quad (18)$$

meaning that the interest rate r^b depends negatively on the repayment rate α . The reason is that banks are *in fine* not interested in the gross return on loans $r^b/(1+r^b)$ but on the net return which depends positively on the firm repayment rate. Interest rate and repayment rate are (imperfect) substitute in the borrowing banks net return. From this we can infer that an increase in the demand for loans following a positive shock will (i) decrease the firms default rate, i.e. the risk incurred by the merchant bank, (ii) which yields a relatively lower price of loans for firms and (iii) increases further their loans demand. This typically reproduces the mechanism of a financial accelerator. Would we impose α to be fixed, the substitution effect in the composition of the borrowing banks net return would disappear, and the financial accelerator would collapse.

The same mechanism can be described on the interbank market (imperfect substitution between δ and i) and leads to the second accelerator of the model. From this twin mechanism, we see that the above described model allows for a potential contagion and amplification of banking sector shock to the real activity and *vice versa*. This confirms alternative approaches showing the importance of credit market imperfections to accelerate shocks, see for instance Bernanke et al. (1999) with asymmetry of information and agency costs or Wasmer and Weil (2004) with sequential search and matching processes.

As an illustration, we conduct two alternative simulations with a positive productivity shock (TFP shock for the firm). In the first simulation the firm and bank repayment rates are exogenous and in the second, the firm and bank repayment rates are endogenous. Figure 2 shows that the positive shock increases firm and bank repayment rates which in turn limit the rise

in r_t^b and i_t , amplifying the productivity shock and stimulating further employment and output.²¹ Quantitatively, endogenous defaults accelerate employment and output fluctuations by respectively 10% and 5%.

4.3 The Basel regulation

According to the Basel regulation, banks must hold capital reserves (own funds) appropriate to the risk the banks expose themselves to through their lending and investment practices. But concern emerged about the possibility of negative impact that capital requirements could exert on bank loans and economic activity.²² To answer this question, we check with our model how capital requirements affect the steady state and the resilience to shocks. More recently, Basel regulation was modified to make minimum capital standards more risk-sensitive (the so-called “Basel II” regulation). Again, concerns have been raised that this new regulation will exacerbate business cycle fluctuations and we use our model to examine this.²³

4.3.1 Own fund requirements: steady state vs. dynamics

In data and in our calibration, the minimum ratio of capital to risk weighted assets is $k = 8\%$. We instead assume a “Basel-free” economy ($k \rightarrow 0$), a “Basel-full” economy ($k = 15\%$) and we compute the steady state change of moving from Basel-free to Basel-full. Table 4 shows that stricter capital requirements obviously increases own funds, which in turn reduces the loan supply (both on the credit market and the interbank market). This raises the two associated interest rates and these higher credit costs lower repayment rates. In the end, economic activity shrinks by 0.3%. This is in line with empirical studies although our quantitative results are relatively low.

If Basel-type regulation is prejudicial to long-run growth, it nevertheless allows to limit business cycle fluctuations. As shown in Figure 3, after a similar productivity shock, fluctuations are dampened in the Basel-full economy (with respect to the Basel-free economy). Indeed, a positive productivity shock stimulates loan supply but this increase is limited in case of Basel-full, because a fraction of it must be kept as own funds. Interest rates are further raised and this reduces - weakly - employment and GDP fluctuations by respectively 5% and 2%.

²¹In fact, if the rise in i_t is well reduced by the lower bank default, there is a second effect playing in opposite direction. The fall in firm default and hence in r_t^b stimulates credit demand by firms and banks are forced to find extra liquidities on the interbank market, which increases the interbank rate. In our simulations, the second effect is higher than the first and this explains the fourth plot of Figure 2.

²²See for instance Berger and Udell (1994), Brinkmann and Horwitz (1995) or Hancock et al. (1995) for US empirical evidence.

²³See for instance Kashyap and Stein (2004) for a discussion and a review of previous works.

4.3.2 From Basel I to Basel II

Let us first assess the effects of introducing risk-sensitive capital requirements for the merchant banks from a steady state analysis. After an increase in α (positive or procyclical shock), the capital adequacy requirement for the merchant banks remains unchanged under Basel I whereas capital requirement decreases under Basel II. In other words, a higher α implies $\bar{\omega}_{II} < \bar{\omega}_I$. From the loan supply first order condition (18), we obtain:

$$\frac{1}{1 + r_I^b} - \frac{1}{1 + r_{II}^b} = \frac{d_{Fbk}}{\lambda^b} (\bar{\omega}_{II} - \bar{\omega}_I). \quad (19)$$

It is straightforward that $\bar{\omega}_{II} < \bar{\omega}_I \Rightarrow r_{II}^b < r_I^b$, meaning that after a positive shock on α , the borrowing rate will be lower under a Basel II regulation than under a Basel I regulation. From the loan demand first order condition (18), it also means that L^b and hence GDP and employment will be further stimulated with a Basel II regulation.²⁴

Would this partial equilibrium result on the procyclicality of Basel II be confirmed in our general equilibrium setup? We let $\bar{\omega}_t$ vary negatively with firms expected repayment rate α_{t+1} as displayed on equation (15) with $\eta = 100$. This value allows realistic variation of the weight (10% variation for a 1% GDP fluctuation). Figure 4 shows that, under Basel II, the effect of α_{t+1} on $\bar{\omega}_t$ acts as an extra positive shock on loans supply, reducing further the borrowing rate r_t^b . From the firm's first order condition (A3), this enhances the demand for loans which further stimulates GDP and employment. Our dynamic general equilibrium setup therefore confirms the procyclical effect, *i.e.* multiplier effect amplifying the effects of the shock, of Basel II type of regulations (about a 1% acceleration of GDP fluctuations).

In general, we see that the quantitative effects of the Basel regulation are weak. One reason, as already underlined by Heid (2007) with a static partial equilibrium model, is that they are mitigated by the buffer banks hold on top of the required minimum capital.

5 An illustration: the subprime crisis

The subprime mortgage crisis was initially triggered by a dramatic rise in mortgage delinquencies. Banks that had heavily invested in mortgage backed-securities sustained large losses in their market book, which in turn led to a generalized credit tightening. To avoid an even more severe credit crunch, the Fed flooded the interbank market with liquidities. In this section, we use our model to understand how an adverse market book shock may spread to the whole economy and what are the effects - both in the short- and the long-run - of liquidity injections. To do so, we set the productivity shock to its steady state value but instead introduce

²⁴A Basel II regulation on interbank loans (see footnote 12) would of course produce the same procyclical effects.

$\rho_t = (\rho)^{1-\rho_\rho} (\rho_{t-1})^{\rho_\rho} \exp(-u_t^\rho)$. We set the autoregressive parameter at 0.50 and have normally distributed innovations with variance 0.01.

5.1 Market book shock and liquidity injections

Figure 5 displays the impulse response function for some variables with $\nu = 0$ (no injections). The fall in market book return (it amounts to an initial fall in bank total assets of 0.6%) dries the interbank market and equilibrium is only restored through higher interbank rates (they increase from 2.8% to 2.9% in annual terms). Loans to firms also decline by 0.3% and render capital more expensive for firms (from 6.6% to 6.7%). Defaults increase for both firms and banks, and GDP shrinks by 0.2%. This clearly shows the strong links between the banking sector and the rest of the economy and is usually referred to as the “credit crunch” story. Liquidity injections ($\nu = 50$, implying that central bank interventions represent on average 10% of the interbank market volume) modify the reaction of the economy after this - negative - market book shock. Initially the central bank favors the borrowing bank, supplying liquidities and preventing the interbank rate to spike. As a result, it also supports loan supply to firms L_t^b , inducing a lower increase in the credit rate and a lower fall in the firms repayment rate α_t . *On the short term*, the effects of the market book shock are therefore strongly reduced by liquidity interventions, with the GDP fall divided by 2.

Beside this impact effect, the central bank intervention has a delayed effect. Money injections maintain artificially low interbank loans by lending banks, and this makes the disequilibrium more persistent. A more persistent disequilibrium means interest rates remain above equilibrium for longer, with the consequence that after some periods, the initial economy stabilizing effect of the injection will turn into a procyclical one. This is clearly illustrated in Figure 5: the fall in the repayment rate α_t is reduced by the central bank intervention in the short run. But from the moment money supply brings the interbank interest rate above what it would have been in the absence of intervention, α_t is below its no-intervention level. As a result, *in the long run*, liquidity interventions increase the persistence of the shock - negative - effects on economic activity.

5.2 Optimal monetary policy

Since we have positive short-run effects and negative long-run effects, at least for GDP, we wonder what would be the optimal rule for liquidity injections in case of market book shocks, that is what would be the optimal ν in:

$$M_t = \nu (i_t - \bar{i}).$$

We assume that the central bank may follow two objectives: GDP stability and financial stability. In the first case the stabilization goal is to minimize a quadratic loss function of the form:

$$\mathcal{L}_0^{gdp} = \sum_{t=0}^{\infty} \beta^t E_0 \left[(g\hat{d}p_t)^2 \right],$$

i.e. the central bank minimizes output fluctuations as in Woodford (2003).²⁵ Alternatively, we assume that the central bank is directly interested in financial stability and seeks to minimize bank default fluctuations:

$$\mathcal{L}_0^{\delta} = \sum_{t=0}^{\infty} \beta^t E_0 \left[(\hat{\delta}_t)^2 \right].$$

In Figure 6, we plot the values of \mathcal{L}_0^{gdp} and \mathcal{L}_0^{δ} , obtained by simulating a second order approximation to the model, for different values of ν . We see that a higher interbank rate stability (that is a higher ν) increases financial stability. This result is intuitive since the bank default rate $1 - \delta_t$ directly depends on the interbank rate, see equation (A6). The effect of a higher interbank rate stability on output stability is ambiguous: depending on the importance of the ν parameter, central bank interventions according to a simplified McCallum rule may either increase or decrease the volatility of the economic activity. Indeed, section 5.1 shows that liquidity injections stabilize the economy in the short run but not in the long run. The total resulting effect depends on the relative importance these two opposite forces.²⁶

Finally, moving from a Basel I regime to a Basel II regime helps to reduce further financial instability (the curve moves left) but increases output instability (the curve moves up). This last result is obvious because of the procyclicality of Basel II, see section 4.3.2 for a discussion.

6 Conclusion

Over the past decade, financial stability issues have become an important research field for academics and a very visible objective for policymakers and central banks. A majority of central banks and several international financial institutions, such as the IMF and the BIS, have begun publishing regular reports on this field. However, most of this research and analysis remain descriptive and/or based on partial equilibrium analysis. We think that a consistent framework for financial stability analysis must account for all linkages and diffusion processes, not only between financial and non-financial sectors, but also within the financial sector itself.

In this paper, we propose a dynamic stochastic general equilibrium model (related to the RBC literature) with an heterogeneous banking sector and endogenous default rates as in Goodhart

²⁵Since we do not have a nominal model, the central bank objective obviously does not include price fluctuations.

²⁶ $\nu = 200$ means that on average, central bank interventions represent 40% of the interbank market volume. Pushing ν above 200 would not stabilize much further GDP or δ (the marginal effect of a higher ν becomes very weak).

et al. (2005). We show that this model is promising in reproducing US stylized facts. We also discuss the role of the Basel regulation as well as the effects of liquidity injections in case of adverse shocks.

This model is relatively simple and could be extended along several directions. First, we here only focus on monetary injections, leaving aside the other main central bank policy instrument: the fixation of the repurchase rate. Proper representation of central bank behavior (auctions at a central bank determine repo rate and market-determined interbank rate with possibility of - liquid - central bank interventions) would be interesting although probably not trivial. Second, we have no nominal dimension in our model. An extension to a New-Keynesian framework (perfectly competitive firms need to be replaced by monopolistic wholesalers setting Calvo prices and selling intermediate goods to perfectly competitive retailers) would make it possible to study the effects of central bank behavior on inflation (and therefore to include inflation into the loss function). We leave these works for future research.

References

- Berger, A. and G. Udell (1994). Did risk-based capital allocate bank credit and cause a “credit crunch” in the United States? *Journal of Money, Credit and Banking* 26(3), 585–628.
- Bernanke, B., M. Gertler, and S. Gilchrist (1999). The financial accelerator in a quantitative business cycle framework. In J. Taylor and M. Woodford (Eds.), *Handbook of Macroeconomics*, Volume 1C, Chapter 21, pp. 1341–1393. Amsterdam: North-Holland.
- Borio, C. and H. Zhu (2007). Capital regulation, risk-taking and monetary policy: A missing link in the transmission mechanism? BIS.
- Brinkmann, E. and P. Horwitz (1995). Risk-based capital standards and the credit crunch. *Journal of Money, Credit and Banking* 27(3), 848–863.
- Carlstrom, C. and T. Fuerst (1997). Agency cost, net worth, and business fluctuations: A computable general equilibrium analysis. *American Economic Review* 87(5), 893–910.
- Christiano, L., R. Motto, and M. Rostagno (2007). Financial factors in business cycle. mimeo, ECB and Northwestern University.
- Cooley, T., R. Marimon, and V. Quadrini (2004). Aggregate consequences of limited contract enforceability. *Journal of Political Economy* 112, 817–847.
- Dubey, P., J. Geanakoplos, and M. Shubik (2005). Default and punishment in general equilibrium. *Econometrica* 73(1), 1–37.
- Elul, R. (2008). Collateral, credit history, and the financial decelerator. *Journal of Financial Intermediation* 17, 63–88.
- Gerali, A., S. Neri, L. Sessa, and F. Signoretti (2008). Credit and banking in a DSGE model. mimeo, Bank of Italy.
- Goodfriend, M. and B. B. McCallum (2007). Banking and interest rates in monetary policy analysis: A quantitative exploration. *Journal of Monetary Economics* 54, 1480–1507.
- Goodhart, C., P. Sunirand, and D. Tsomocos (2005). A risk assessment model for banks. *Annals of Finance* 1(2), 197–224.
- Goodhart, C., P. Sunirand, and D. Tsomocos (2006). A model to analyse financial fragility. *Economic Theory* 27, 107–142.
- Hancock, D., A. Laing, and J. Wilcox (1995). Bank capital shocks: Dynamic effects on securities, loans, and capital. *Journal of Banking and Finance* 19, 661–677.

- Heid, F. (2007). The cyclical effects of the Basel II capital requirements. *Journal of Banking and Finance* 31(12), 3885–3900.
- Iacovello, M. (2005). House prices, borrowing constraints and monetary policy in the business cycle. *American Economic Review* 95(3), 739–764.
- Kashyap, A. and J. Stein (2004). Cyclical implications of Basel ii capital standards. *Federal Reserve Bank of Chicago Economic Perspectives* 1, 18–31.
- King, R. and S. Rebelo (1999). Resuscitating real business cycles. In J. Taylor and M. Woodford (Eds.), *Handbook of Macroeconomics*, Volume I B, Chapter 14. Amsterdam: North-Holland.
- Kiyotaki, N. and J. Moore (1997). Credit cycles. *Journal of Political Economy* 105, 211–248.
- Maechler, A., S. Mitra, and D. Worrell (2007). Decomposing financial risks and vulnerabilities in Eastern Europe. IMF Working Paper No. WP/07/248.
- Markovic, B. (2006). Bank capital channels in the monetary transmission mechanism. Bank of England Working Paper no. 313.
- McCallum, B. (1994). A reconsideration of the uncovered interest rate parity relationship. *Journal of Monetary Economics* 33, 105–132.
- Meh, C. and K. Moran (2004). Bank capital, agency costs, and monetary policy. Bank of Canada Working Paper 2004-6.
- Modigliani, F. and M. Miller (1958). The cost of capital, corporation finance and the theory of investment. *American Economic Review* 48(3), 261–297.
- Shubik, M. and C. Wilson (1977). The optimal bankruptcy rule in a trading economy using fiat money. *Zeitschrift fur Nationalokonomie* 37, 337–354.
- Stock, J. and M. Watson (1999). Business cycle fluctuations in US macroeconomic time series. In J. Taylor and M. Woodford (Eds.), *Handbook of Macroeconomics*, Volume I, Chapter 1. Amsterdam: North-Holland.
- VanHoose, D. (2008). Bank capital regulation, economic stability, and monetary policy: What does the academic literature tell us? *Atlantic Economic Journal* 36, 1–14.
- Wasmer, E. and P. Weil (2004). The macroeconomics of labor and credit market imperfections. *American Economic Review* 94(4), 944–963.
- Woodford, M. (2003). *Interest and Prices*. Princeton University Press.

A First order conditions

A.1 Firms

The optimization yields the following first order conditions, with λ_t defined as the shadow value of capital:

$$\epsilon_t \mathcal{F}_{N_t} = w_t, \quad (\text{A1})$$

$$\epsilon_t \mathcal{F}_{K_t} = \lambda_t - E_t [\tilde{\beta}_{t+1}(1 - \tau)\lambda_{t+1}], \quad (\text{A2})$$

$$\frac{\lambda_t}{1 + r_t^b} = E_t [\tilde{\beta}_{t+1}\alpha_{t+1} + \tilde{\beta}_{t+2} \gamma(1 - \alpha_{t+1})^2 L_t^b], \quad (\text{A3})$$

$$L_{t-1}^b = E_t \left[\tilde{\beta}_{t+1} \gamma(1 - \alpha_t) \left(L_{t-1}^b \right)^2 \right] + d_f. \quad (\text{A4})$$

Equation (A1) equalizes the marginal productivity of labor and wages. Equation (A2) defines the marginal productivity of capital as its shadow value today minus its discounted shadow value tomorrow, and equation (A3) says that the shadow value of capital today is equal to its discounted expected cost (a fraction α_t will be paid back tomorrow and a cost on the remaining fraction will be paid two periods ahead). Equation (A4) equalizes the marginal cost of paying back today to the discounted marginal search cost of tomorrow plus the marginal disutility term.

A.2 Merchant banks

The maximization program yields:

$$\lambda_t^b D_{t-1}^{bd} = E_t \left[\tilde{\beta}_{t+1} \lambda_{t+1}^b \omega^b (1 - \delta_t) \left(D_{t-1}^{bd} \right)^2 \right] + d_\delta, \quad (\text{A5})$$

$$\frac{\lambda_t^b}{1 + i_t} = E_t \left[\tilde{\beta}_{t+1} \lambda_{t+1}^b \delta_{t+1} + \tilde{\beta}_{t+2} \lambda_{t+2}^b \omega^b (1 - \delta_{t+1})^2 D_t^{bd} \right], \quad (\text{A6})$$

$$\frac{\lambda_t^b}{1 + r_t^b} = E_t \left[\tilde{\beta}_{t+1} \lambda_{t+1}^b \alpha_{t+1} + \zeta_b \tilde{\beta}_{t+2} \lambda_{t+2}^b (1 - \alpha_{t+1}) \right] - d_{Fb} k \bar{w}_t, \quad (\text{A7})$$

$$d_{Fb} v_b = \left(\lambda_t^b - \frac{1}{\pi_t^b} \right) - E_t \left[\tilde{\beta}_{t+1} (1 - \zeta_b) \left(\lambda_{t+1}^b - \frac{1}{\pi_{t+1}^b} \right) \right]. \quad (\text{A8})$$

The Lagrange multiplier associated with the constraint (7) is represented by λ_t^b . Equation (A5) is the trade off between paying back today and paying a cost tomorrow. Equations (A6) and (A7) are Euler equations respectively for borrowing (from the interbank market) and lending (to firms).

A.3 Deposit banks

The maximization program yields:

$$\frac{\lambda_t^l}{1+r_t^l} = E_t \left[\tilde{\beta}_{t+1} \lambda_{t+1}^l \right], \quad (\text{A9})$$

$$\frac{\lambda_t^l}{(1+i_t)} = E_t \left[\tilde{\beta}_{t+1} \lambda_{t+1}^l \delta_{t+1} + \zeta_l \tilde{\beta}_{t+2} \lambda_{t+2}^l (1-\delta_{t+1}) \right] - d_{Fl} k \bar{v}, \quad (\text{A10})$$

$$d_{Fl} v_l = \left(\lambda_t^l - \frac{1}{\pi_t^l} \right) - E_t \left[\tilde{\beta}_{t+1} (1-\zeta_l) \left(\lambda_{t+1}^l - \frac{1}{\pi_{t+1}^l} \right) \right]. \quad (\text{A11})$$

The Lagrange multiplier associated with the constraint (10) is represented by λ_t^l . Equations (A9) and (A10) are Euler equations for respectively deposits (from households) and loans (to the interbank market).

A.4 Households

The maximization program yields:

$$\frac{\mathcal{U}_{C_t}}{1+r_t^l} = \beta E_t [\mathcal{U}_{C_{t+1}}] - \chi \left(\frac{D_t^l}{1+r_t^l} - \frac{\bar{D}^l}{1+r^l} \right), \quad (\text{A12})$$

$$\frac{\bar{m} C_t}{1-N_t} = w_t. \quad (\text{A13})$$

Equation (A12) is the Euler equation for consumption augmented with the deposit target term and equation (A13) is the labor supply first order condition.

B Real data

B.1 Computation and sources

Real quarterly US data from 1985Q1 to 2008Q2. Nominal data are deflated by the GDP deflator (stock and flow data) or the CPI (financial data). More precisely:

- Interbank loans: include all loans and advances to credit institutions, Fed funds and RPs with banks, repayable on demand or with agreed maturity. Data from the quarterly aggregated and seasonally adjusted balance sheet of commercial banks in the United States. Source: Federal Reserve System statistics.
- Market book: includes treasury and agency securities and other fixed and variables securities. Data from the quarterly aggregated and seasonally adjusted balance sheet of commercial banks in the United States. Source: Federal Reserve System statistics.

- Loans to firms: include commercial and industrial loans and real estate loans for commercial activities. Data from the quarterly aggregated and seasonally adjusted balance sheet of commercial banks in the United States. Source: Federal Reserve System statistics.
- Others (assets): defined as the difference between total assets and the sum of market book, interbank loans and loans to firms.
- Interbank deposits: include all borrowings from banks. Data from the quarterly aggregated and seasonally adjusted balance sheet of commercial banks in the United States. Source: Federal Reserve System statistics.
- Consumer deposits: include transaction and non-transaction deposits. Data from the quarterly aggregated and seasonally adjusted balance sheet of commercial banks in the United States. Source: Federal Reserve System statistics.
- Own funds: defined as subscribed capital plus reserves including past profits bring forward. Because of the lack of data on these components, own funds are approximated by the gap (residual) between total assets and liabilities. Source: Federal Reserve System statistics.
- Profits: quadratic interpolation of commercial bank annual profits data, published by the Federal Deposit Insurance Corporation (FDIC), Table CB 04.
- Others (liabilities): data from the quarterly aggregated and seasonally adjusted balance sheet of commercial banks in the United States. Source: Federal Reserve System statistics.
- Lending rate: quarterly average of monthly interest rates on certificate deposits (non-transaction deposits) minus 100 basis points. Source: Federal Reserve System statistics, series H 15. This adjustment is justified by the existence of transaction deposits paying lower interest rates. The size of this adjustment is chosen from the monthly survey of FRBSF regarding the interest rates on deposits and loans.
- Interbank rate: quarterly average of daily data on London interbank offered rate for US dollar. Source: Bloomberg, series US0003M.
- Borrowing rate: quarterly average of monthly interest rates on bank prime loans plus 150 basis points. Source: Federal Reserve System statistics, series H 15. This adjustment is justified by the existence of borrowers riskier than prime ones. The size of this adjustment is chosen from the monthly survey of FRBSF regarding the interest rates on deposits and loans.
- Default rate for banks (Z-score, see Appendix C for details): calculated from aggregated and seasonally adjusted balance sheet of commercial banks in the United States (Federal Reserve System) and interpolated annual profit (FDIC).

- Default rate for banks (BLS): quarterly and seasonally adjusted number of closings (source: BLS, series financial activities, 1992-2008) divided by the number of financial institutions (quadratic interpolation of yearly data, source: US courts).
- Default rate for banks (FDIC): own computation of quarterly and seasonally adjusted number of commercial bank failures (based on declared date of bank failure, seasonally adjusted with Census X12, source: FDIC) divided by the number of commercial banks (quadratic interpolation of yearly data, source: FDIC).
- Default rate for firms (US courts): ratio of the quarterly number companies failure (seasonally adjusted with Census X12, source: US courts) to the total number of firms (quadratic interpolation of yearly data, source: US courts).
- Default rate for firms (BLS): quarterly and seasonally adjusted number of closings (source: BLS, series total private industry, 1992-2008) divided by the total number of firms (quadratic interpolation of yearly data, source: US courts).
- Default rate for firms (bad loans): ratio of commercial loan charge-off for all banks to total of commercial loans. Source: Federal Reserve Bank of St. Louis, seasonally adjusted quarterly data.
- Investment: seasonally adjusted quarterly real private fixed investment. Source: Bureau of Economic Analysis.
- Consumption: seasonally adjusted quarterly real private consumption. Source: Bureau of Economic Analysis.
- Gross Domestic Product: seasonally adjusted quarterly real gross domestic product. Source: Bureau of Economic Analysis.
- Employment: quarterly employment in the non farm business sector. Source: Bureau of Labor Statistics.

B.2 Banks balance sheet

Figure 7 depicts an aggregate balance sheet for the US banking sector (average 1985Q1-2008Q2).

B.3 Link between sectors: further empirical evidence

How far firm investment is dependant from the banking sector credit? Because we do not have data on new loans to firms (flow), we compare investment to the stock of existing loans.

Figure 8 shows that the two series have a similar volatility and are closely related, suggesting a close tie between firms and banks.²⁷

In section 3.2, we define the firm default rate by the ratio of bankruptcies to the total number of firms. The Federal Reserve Bank of Saint-Louis provides data on bad loans (that we divide by the total amount of commercial loans) and we obtain an average of 0.5%, *i.e.* a much lower number than the 5% we obtain from bankruptcy data. However, as shown in Figure 9, it is interesting to see that these two series are closely related, suggesting again a close link between sectors.

C Z-score: an application to US bank default

The Z-score index is a distance to default indicator (DD) calculated from bank's balance sheet and profit account (rather than an option-based measure as the standard DD indicator). The advantage of the Z-score (book value) relative to DD (market value) is the possibility to evaluate the default risk of non listed companies.

The Z-score is defined as $z = (\mu + k)/\sigma$, where μ is the average return on assets (ROA), k is the ratio of own funds to total assets, and σ is the ROA standard deviation. In other words, the Z-score measures the number of standard deviations a return realization would have to fall in order to deplete banks' own funds, under the assumption of normality of returns. As with DD, the higher level of the Z-score the better is quality of the bank and the lower is the probability of insolvency.

In this paper, we derived the Z-score for the US aggregated banking sector from quarterly financial statements. The sample period covers 1985Q1 to 2008Q2. We adopt the Maechler et al. (2007) approach and use a eight-quarter rolling Z-index calculated from the 8 quarters moving average of the three above mentioned variables. We then take the logarithm of the result to get z .

As the Z-score is, by assumption, normally distributed with a mean zero and a standard deviation equal 1, the probability of default of the banking sector at time t is $P_t = F(-z_t)$, where F is the cumulative distribution.

²⁷We start in 1988 because of a structural break in the credit series (commercial real estate was not included before 1988). We also see that the credit series lags the investment series. One possible explanation is that investment is a flow whereas credit is a stock.

D Business cycle moments with productivity and market book shocks

We keep the productivity shock detailed in section 4, but we now also add a market book shock. More precisely, we define $\rho_t = (\rho)^{1-\rho} (\rho_{t-1})^{\rho} \exp(u_t^{\rho})$. We set the autoregressive parameter at 0.50, the innovations are normally distributed and the variance is chosen such that 25% of GDP fluctuations are explained by the market book shock (that is the remaining 75% are explained by the productivity shock). We also assume that productivity and market book innovations have a 65% correlation. New moments are displayed in Table 5.

A positive market book shock increases profits and hence own funds, and the negative effect due to the productivity shock is more than offset. It also raises the volatility of profits and own funds. Globally, the second moments of the banking sector are strongly improved, underlying the - obvious - fact that a productivity shock alone is not sufficient to reproduce business cycle properties of the banking sector.

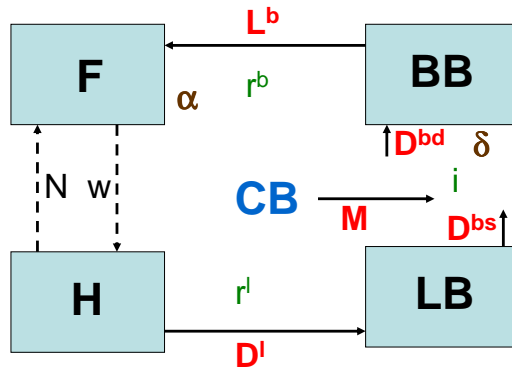

Figure 1: Flows between agents

Banks											
k	=	0.08	$\bar{\omega}$	=	0.8	$\bar{\omega}$	=	0.05	$\bar{\omega}$	=	1.20
d_δ	=	6.67	ω^b	=	679	\bar{B}^b	=	0.19	\bar{B}^l	=	0.19
d_{F^b}	=	6.71	ζ_b	=	0.8	ζ_b	=	0.06	v_b	=	0.5
d_{F^l}	=	53.4	ζ_l	=	0.8	ζ_l	=	0.07	v_l	=	0.5
Firms											
d_f	=	0.05	γ	=	75.4	μ	=	0.333	τ	=	0.03
Households											
β	=	0.996	\bar{m}	=	3.72	\bar{D}^l	=	0.39	χ	=	0.01

Table 1: Calibrated parameter values

Interest and repayment rates

$$r^l = 0.35\% \quad i = 0.7\% \quad r^b = 1.6\% \quad \delta = 0.99 \quad \alpha = 0.95$$

Assets and liabilities

$$\frac{D^l}{L^b} = 2 \quad \frac{D^b}{L^b} = 0.5 \quad \frac{B^b}{L^b} = 1 \quad \frac{F}{B} = 0.25 \quad \frac{B^l}{B^b} = 1$$

Production, penalty costs and profits

$$\begin{aligned} \frac{K}{F} &= 10 & \frac{\pi^f}{F} &= 4\% & \frac{tpcf}{F} &= 0.6\% & \frac{\tau K}{F} &= 0.3\% & \frac{C}{F} &= 0.7 \\ \bar{N} &= 0.2 & \frac{\pi}{F} &= 12\% & \frac{tpcb}{F} &= 0.3 & & & & \end{aligned}$$

$tpcf$ = total penalty costs for firms = $\frac{\gamma}{2} ((1 - \alpha)L^b)^2$, $tpcb$ = total penalty costs for banks = $\frac{\omega^b}{2} ((1 - \delta)D^{bd})^2$, π = total profits for banks = $\pi^b + \pi^l$, F = total own funds = $F^b + F^l$, B = total market book = $B^b + B^l$.

Table 2: Implied values for variables

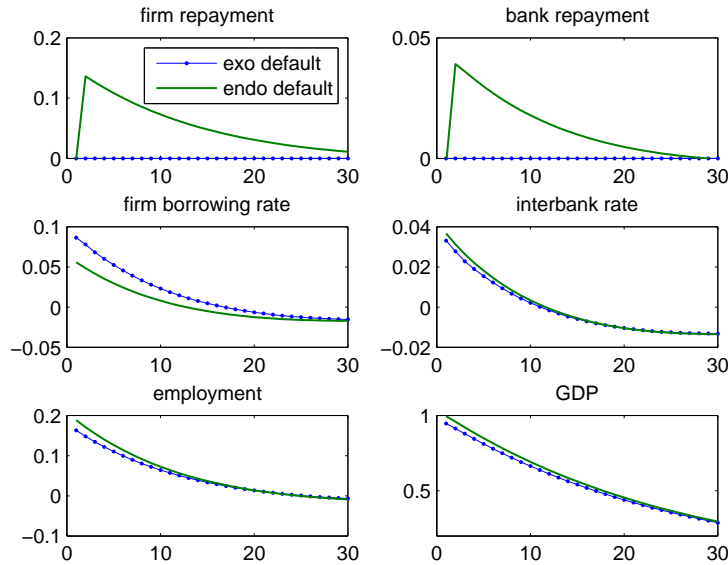

Figure 2: Endogenous repayment rates and size of the financial accelerator

	mean		relative standard deviation		correlation with output		first-order autocorrelation	
	data	model	data	model	data	model	data	model
	r_t^b	6.61	6.49	1.20	0.16	0.36	0.95	0.90
i_t	2.80	2.82	1.20	0.10	0.49	0.94	0.88	0.70
r_t^l	1.70	1.41	1.20	0.12	0.47	0.95	0.88	0.70
α_t	95.4	95.0	0.52	0.09	0.44	0.73	0.82	0.70
δ_t	99.9	99.0	0.01	0.03	0.11	0.71	0.87	0.68
$L_t^b(*)$	0.67	0.29	4.03	2.94	0.36	0.99	0.79	0.71
$D_t^{bd}(*)$	0.49	0.15	6.95	6.18	0.44	0.97	0.87	0.71
$D_t^{bs}(*)$	0.11	0.15	8.21	6.18	-0.24	0.97	0.81	0.71
$D_t^l(*)$	1.59	0.60	1.38	1.45	-0.11	0.99	0.87	0.71
F_t	0.22	0.15	4.62	0.05	0.01	-0.70	0.64	0.96
π_t	0.01	0.02	47.3	0.24	0.13	-0.84	0.78	0.73
gdp_t	1.00	1.00	1.00	1.00	1.00	1.00	0.86	0.72
C_t	0.69	0.70	0.82	0.36	0.81	0.93	0.83	0.79
inv_t	0.20	0.29	4.00	2.94	0.89	0.99	0.92	0.71
N_t	0.20	0.20	1.03	0.61	0.77	0.98	0.96	0.70

All variables have been logged with the exception of the real interest rates and default rates. Interest rates are annualized. Real data: see Appendix B. r_t^b : borrowing rate, i_t : interbank rate, r_t^l : deposit rate, α_t : firm repayment rate, δ_t : bank repayment rate, L_t^b : loans to firms, D_t^{bd} : interbank deposits, D_t^{bs} : interbank loans, D_t^l : consumer deposits, $F_t = F_t^b + F_t^l$: bank own funds, $\pi_t = \pi_t^b + \pi_t^l$: bank profits, $gdp_t = C_t + K_t - (1 - \tau)K_{t-1} + F_t^b + F_t^l - (1 - \zeta_b)F_{t-1}^b - (1 - \zeta_l)F_{t-1}^l$: gross domestic product, C_t : consumption, $inv_t = K_t - (1 - \tau)K_{t-1}$: investment, N_t : employment. Variables marked with (*) are stocks in data but flows in our model (because they all have one-period maturity) and we must remain cautious when comparing (especially steady states).

Table 3: Cyclical properties

F	=	+7%	π	=	-0.3%	gdp	=	-0.3%
L^b	=	-0.3%	α	=	-0.1	r^b	=	+0.4
D^{bs}	=	-51%	δ	=	-0.3	i	=	+0.3

$F = F^b + F^l$: bank own funds, $\pi = \pi^b + \pi^l$: bank profits, $gdp = C + \tau K + \zeta_b F^b + \zeta_l F^l$: gross domestic product

Table 4: Steady state effects of increasing the minimum own funds ratio from $k = 0\%$ to $k = 15\%$

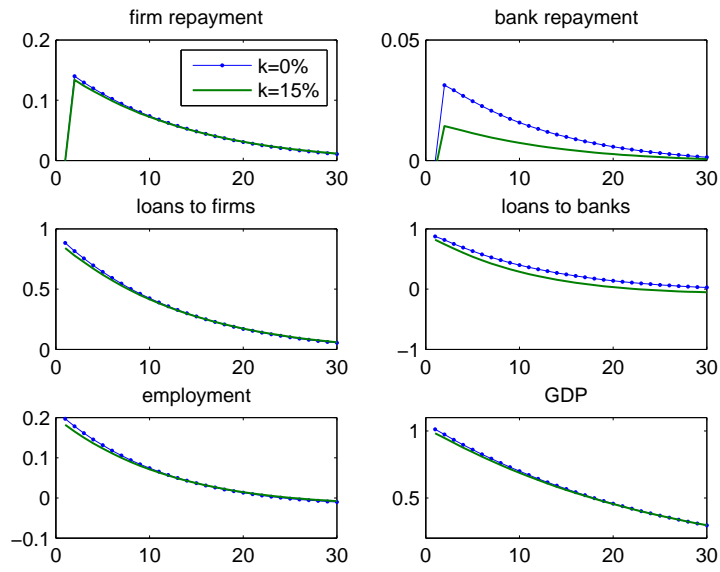

Figure 3: Dynamic effects of minimum own funds ratio

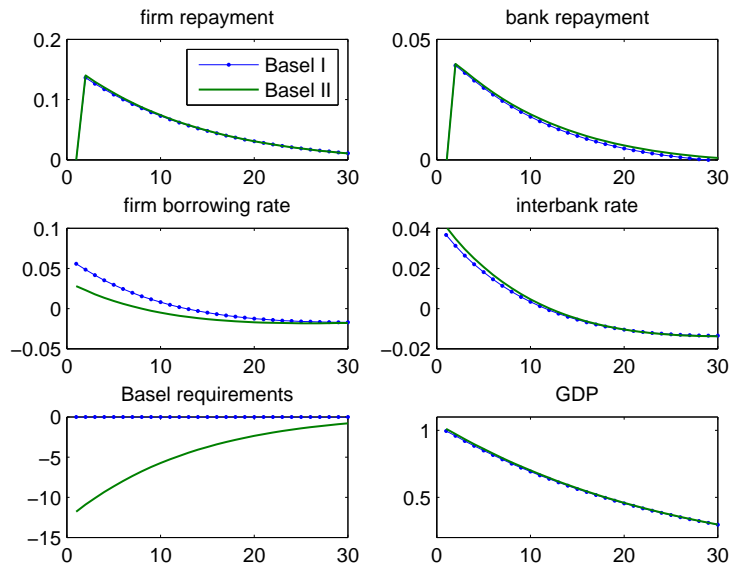

Figure 4: Procyclical effects of Basel II

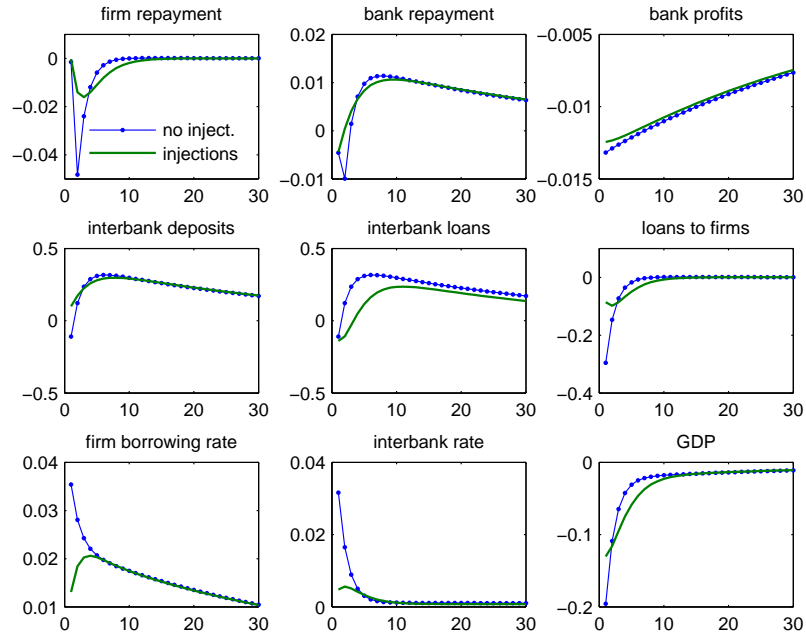

Figure 5: Market book shock and liquidity injections

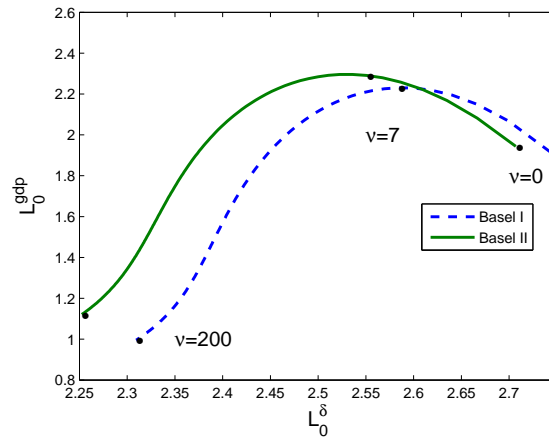

Figure 6: Optimal monetary policy: stabilizing output *vs.* default rate



Figure 7: Aggregate balance sheet of US banks (average 1985Q1-2008Q2)

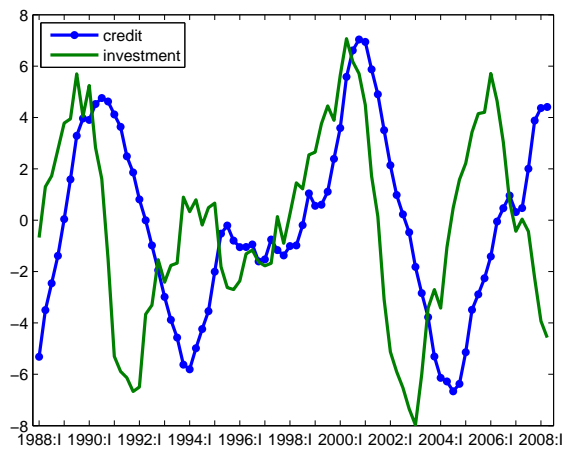

Figure 8: Bank loans to firms (credit) vs. firm investment (deviations from trend)

	mean		relative standard deviation		correlation with output		first-order autocorrelation	
	data	model	data	model	data	model	data	model
	r_t^b	6.61	6.49	1.20	0.12	0.36	0.17	0.90
i_t	2.80	2.82	1.20	0.10	0.49	0.08	0.88	0.49
r_t^l	1.70	1.41	1.20	0.10	0.47	0.26	0.88	0.56
α_t	95.4	95.0	0.52	0.10	0.44	0.66	0.82	0.58
δ_t	99.9	99.0	0.01	0.03	0.11	0.65	0.87	0.61
$L_t^b(*)$	0.67	0.29	4.03	3.32	0.36	0.38	0.79	0.58
$D_t^{bd}(*)$	0.49	0.15	6.95	5.84	0.44	0.75	0.87	0.59
$D_t^{bs}(*)$	0.11	0.15	8.21	5.84	-0.24	0.75	0.81	0.59
$D_t^l(*)$	1.59	0.60	1.38	1.72	-0.11	0.32	0.87	0.76
F_t	0.22	0.15	4.62	0.26	0.01	0.01	0.64	0.96
π_t	0.01	0.02	47.3	1.14	0.13	0.64	0.78	0.73
gdp_t	1.00	1.00	1.00	1.00	1.00	1.00	0.86	0.65
C_t	0.69	0.70	0.82	0.35	0.81	0.93	0.83	0.73
inv_t	0.20	0.29	4.00	3.32	0.89	0.98	0.92	0.58
N_t	0.20	0.20	1.03	0.48	0.77	0.92	0.96	0.75

All variables have been logged with the exception of the real interest rates and default rates. Interest rates are annualized. Real data: see Appendix B. r_t^b : borrowing rate, i_t : interbank rate, r_t^l : deposit rate, α_t : firm repayment rate, δ_t : bank repayment rate, L_t^b : loans to firms, D_t^{bd} : interbank deposits, D_t^{bs} : interbank loans, D_t^l : consumer deposits, $F_t = F_t^b + F_t^l$: bank own funds, $\pi_t = \pi_t^b + \pi_t^l$: bank profits, $gdp_t = C_t + K_t - (1 - \tau)K_{t-1} + F_t^b + F_t^l - (1 - \zeta_b)F_{t-1}^b - (1 - \zeta_l)F_{t-1}^l$: gross domestic product, C_t : consumption, $inv_t = K_t - (1 - \tau)K_{t-1}$: investment, N_t : employment. Variables marked with (*) are stocks in data but flows in our model (because they all have one-period maturity) and we must remain cautious when comparing (especially steady states).

Table 5: Cyclical properties with two shocks

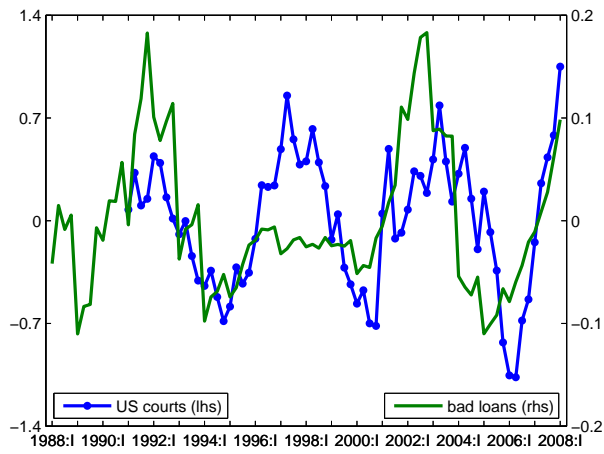

Figure 9: Firm default: bankruptcies (US courts) vs. bad loans (deviations from trend)